



(19) **United States**

(12) **Patent Application Publication**
Tomida

(10) **Pub. No.: US 2015/0221673 A1**
(43) **Pub. Date: Aug. 6, 2015**

(54) **DISPLAY DEVICE, ELECTRO-OPTICAL ELEMENT DRIVING METHOD AND ELECTRONIC EQUIPMENT**

Publication Classification

(71) Applicant: **Sony Corporation**, Tokyo (JP)

(72) Inventor: **Masatsugu Tomida**, Aichi (JP)

(21) Appl. No.: **14/686,844**

(22) Filed: **Apr. 15, 2015**

(51) **Int. Cl.**
H01L 27/12 (2006.01)
G09G 3/30 (2006.01)
H01L 27/15 (2006.01)

(52) **U.S. Cl.**
CPC **H01L 27/124** (2013.01); **H01L 27/1255** (2013.01); **H01L 27/15** (2013.01); **G09G 3/30** (2013.01); **G09G 2300/0404** (2013.01)

Related U.S. Application Data

(63) Continuation of application No. 14/281,193, filed on May 19, 2014, which is a continuation of application No. 13/972,984, filed on Aug. 22, 2013, now Pat. No. 8,743,098, which is a continuation of application No. 13/544,143, filed on Jul. 9, 2012, now Pat. No. 8,553,020, which is a continuation of application No. 12/087,047, filed on Jun. 25, 2008, now Pat. No. 8,237,690, filed as application No. PCT/JP2007/071559 on Nov. 6, 2007.

Foreign Application Priority Data

(30) Nov. 13, 2006 (JP) 2006-306252

(57) **ABSTRACT**

The present invention permits a capacitance value of an electro-optical element such as organic EL element to be arbitrarily set without changing the light extraction efficiency of a pixel. That is, the present invention permits a capacitance value of an organic EL element (21) to be arbitrarily set by adjusting the light emission area of the organic EL element (21) without changing the light extraction efficiency of a pixel (20) in an organic EL display device. The organic EL display device has the pixels (20) arranged in a matrix form. A light extraction opening (56) is formed on the surface of the pixel with a light-shielding film (black matrix) (57). The light extraction opening (56) has an opening area smaller than the light emission area of the organic EL element (21).

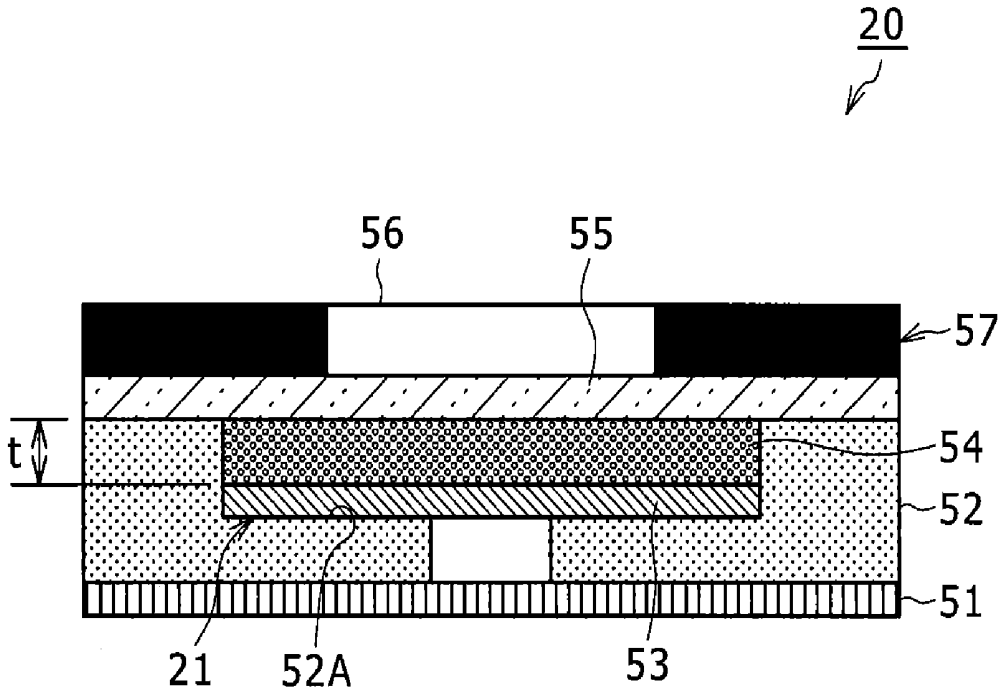

FIG. 2

20

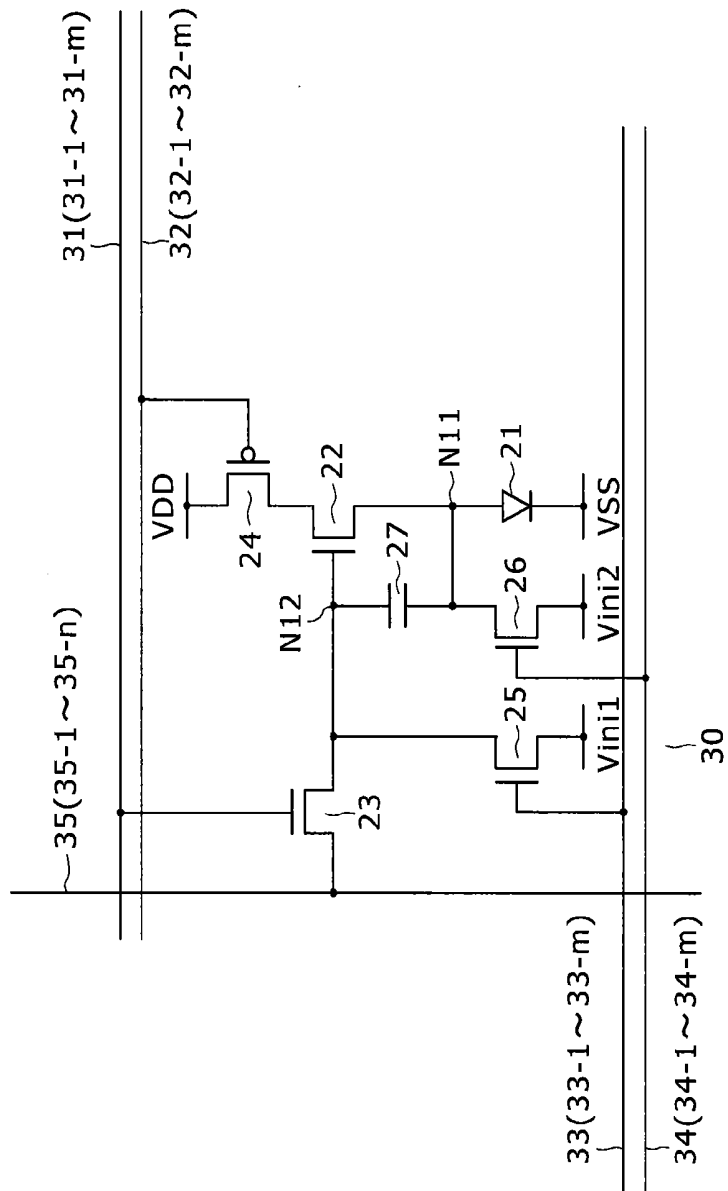
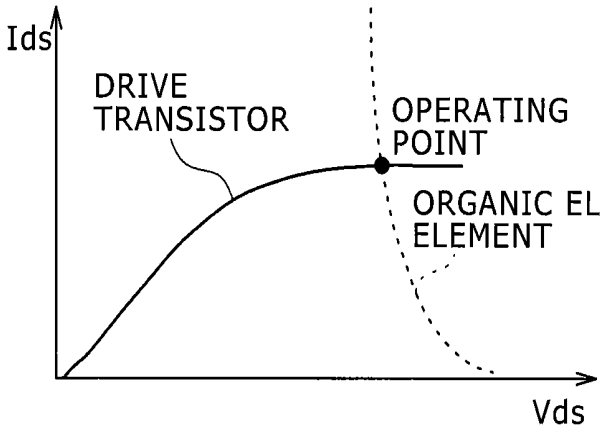

FIG. 3



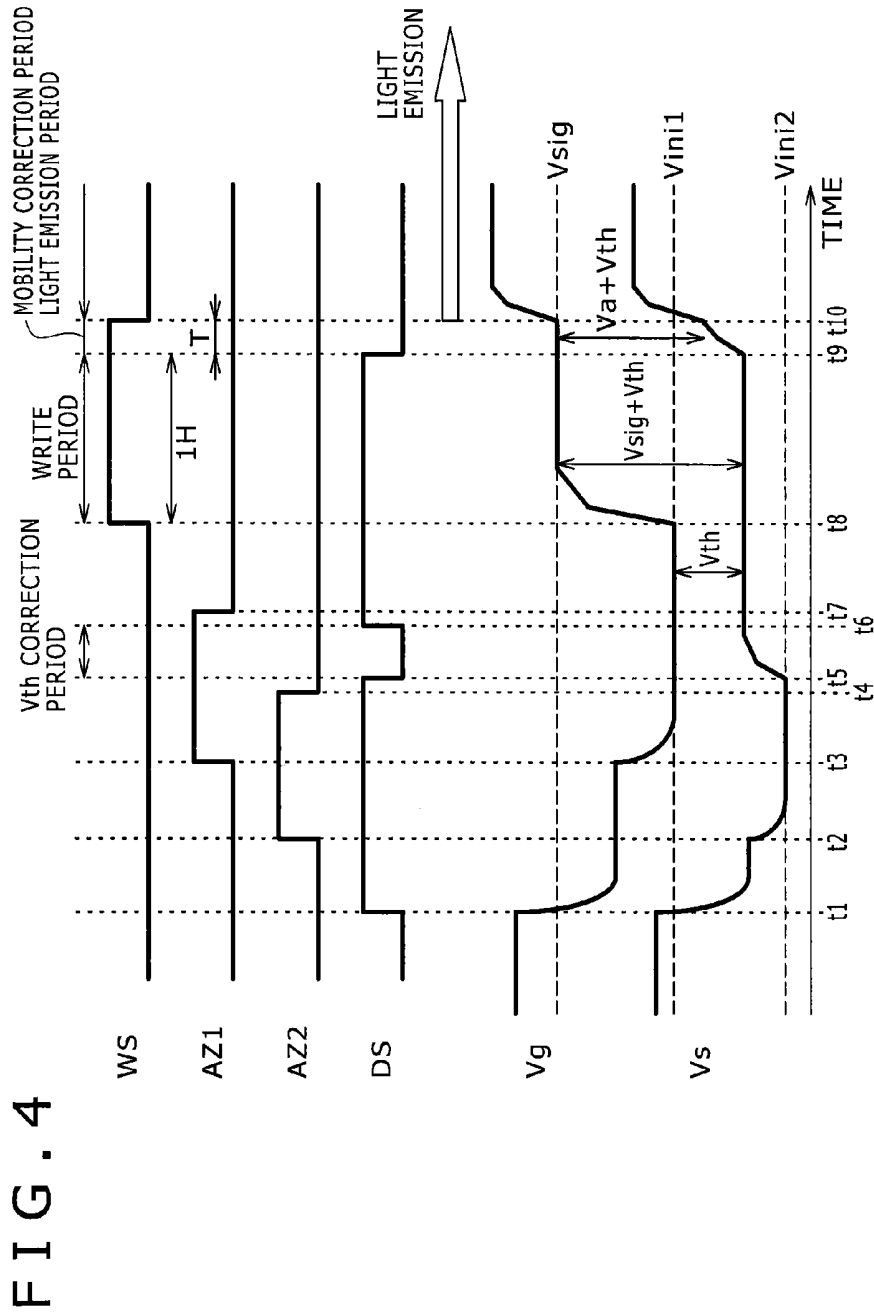

FIG. 5

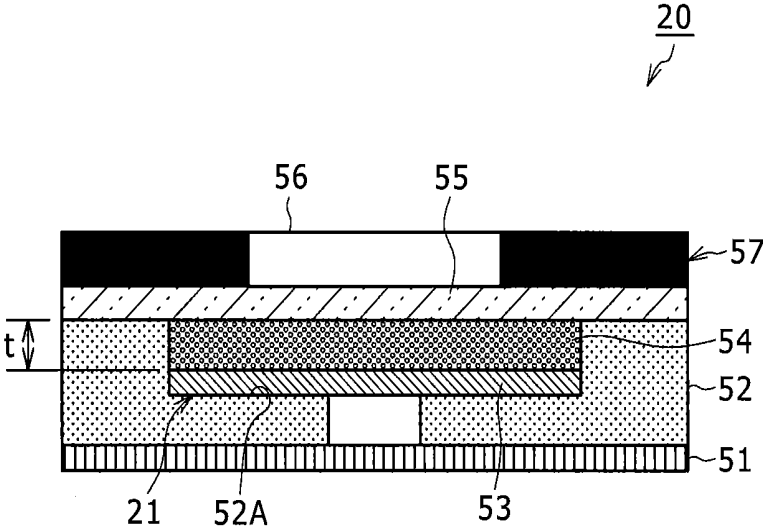
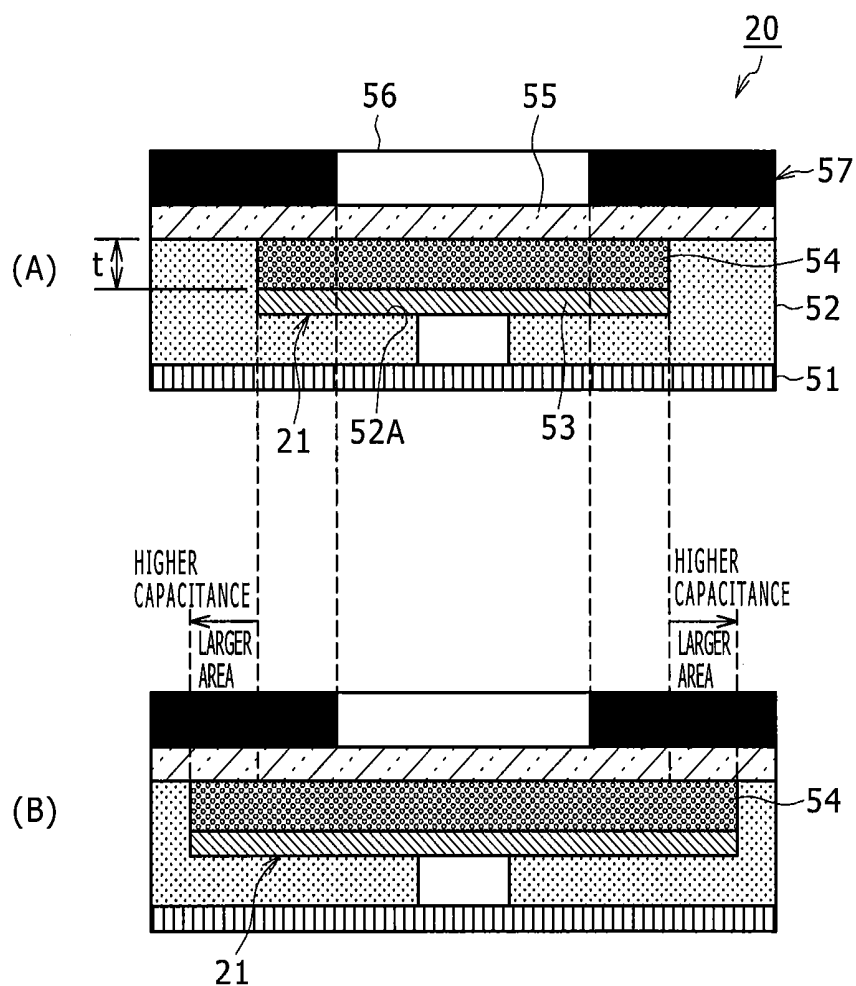

FIG. 6



S07P1529

7/9

FIG. 7

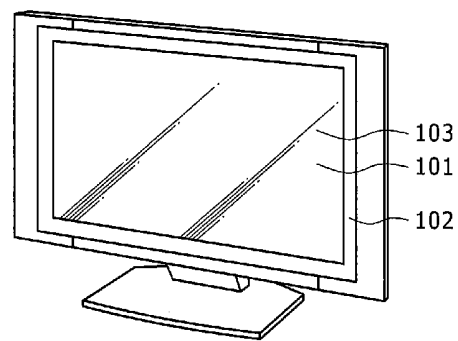
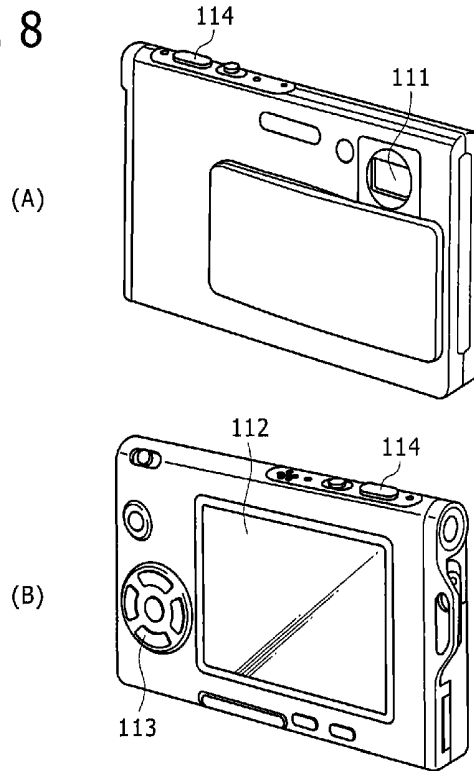

FIG. 8



S07P1529

8/9

FIG. 9

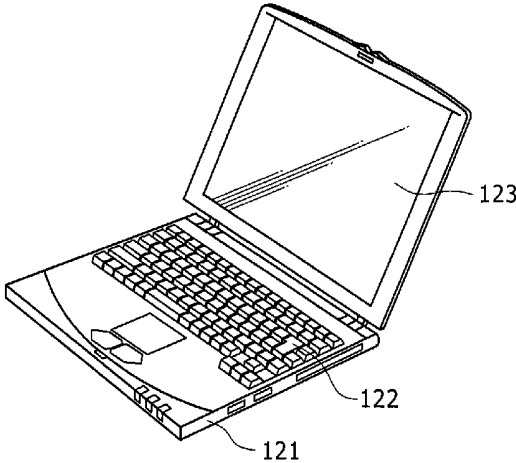
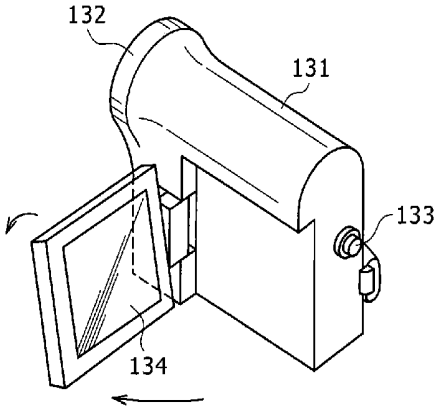
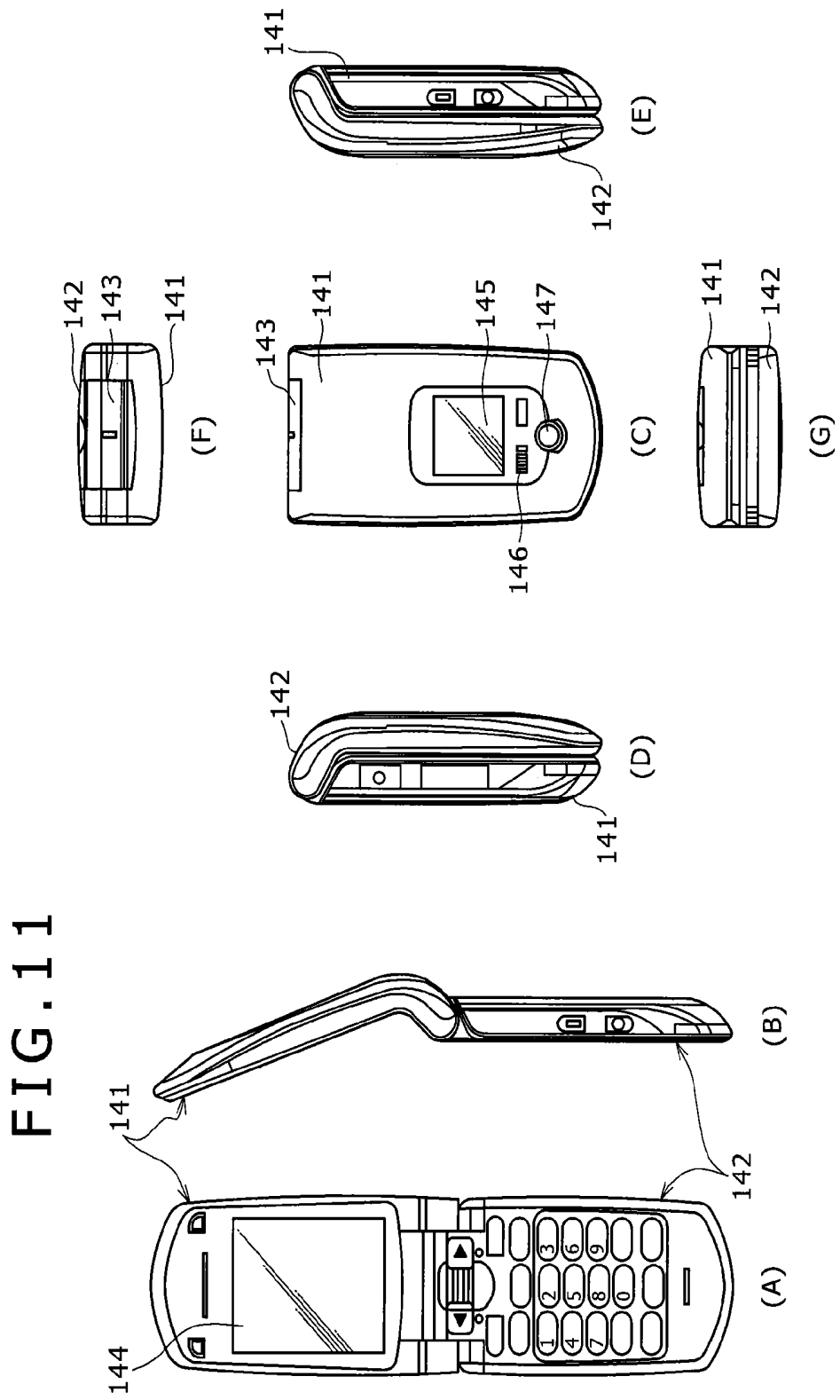

FIG. 10





**DISPLAY DEVICE, ELECTRO-OPTICAL
ELEMENT DRIVING METHOD AND
ELECTRONIC EQUIPMENT**

CROSS REFERENCE TO RELATED
APPLICATIONS

[0001] This Application is a Continuation Application of U.S. patent application Ser. No. 14/281,193, Filed May 19, 2014, which is a Continuation Application of U.S. application Ser. No. 13/972,984, filed Aug. 22, 2013, now U.S. Pat. No. 8,743,098, issued on Jun. 3, 2014, which is a Continuation Application of U.S. patent application Ser. No. 13/544,143, filed Jul. 9, 2013, now U.S. Pat. No. 8,553,020, issued Oct. 8, 2013, which is a Continuation Application of U.S. patent application Ser. No. 12/087,047, filed Jun. 25, 2008, now U.S. Pat. No. 8,237,690, issued Aug. 7, 2012, which is based on a National Stage Application of PCT/JP2007/071559, filed Nov. 6, 2007, which in turn claims priority from Japanese Application No.: 2006-306252, filed on Nov. 13, 2006, the entire contents of which are incorporated herein by reference.

TECHNICAL FIELD

[0002] The present invention relates to a display device having pixels, containing an electro-optical element, arranged in a matrix form, and to an electro-optical element driving method and electronic equipment.

BACKGROUND ART

[0003] In recent years, in the field of image display device for displaying images, organic EL display devices having a number of pixel circuits, containing an electro luminescence element, i.e., organic EL element, which is a so-called current-driven electro-optical element whose light emission brightness changes in accordance with current value flowing through the element, arranged in a matrix form have been developed and commercialized.

[0004] An organic EL element is self-luminous. As a result, an organic EL display device offers several advantages compared with a liquid crystal display device which controls the light intensity from the light source (backlight) by means of pixels, containing liquid crystal cells such as high image visibility, no need for backlight and high response speed of the element.

[0005] An organic EL display device can employ either a simple (passive)-matrix system or an active-matrix system driven as with a liquid crystal display device. It should be noted, however, that a simple matrix display device has some problems although simple in construction. Such problems include such as difficulty in implementing a large high-definition display device.

[0006] For this reason, in recent years, the development of active matrix display devices has been going on at a brisk pace. Such display devices control the current flowing through the electro-optical element with an active element such as insulating gate field effect transistor (typically, thin film transistor; TFT) provided in the same pixel circuit as the electro-optical element.

[0007] In an active matrix organic EL display device, a pixel (pixel circuit) at least includes, in addition to an organic EL element, a drive transistor adapted to drive the organic EL element, a write transistor adapted to sample an input signal voltage and write the voltage to the pixel, and a holding capacitance connected to the gate of the drive transistor to

hold the input signal voltage written by the write transistor (refer, for example, to Japanese Patent Laid-Open Publication No. 2005-345722).

DISCLOSURE OF INVENTION

[0008] In the organic EL display device configured as described above, the drive transistor is designed to operate in the saturation region. Therefore, the drive transistor functions as a constant current source. As a result, a constant drain-to-source current I_{ds} , given by the following formula (1), is supplied to the organic EL element whose anode electrode is connected to the source of the drive transistor:

$$I_{ds} = (1/2) \mu (W/L) C_{ox} (V_{gs} - V_{th})^2 \quad (1)$$

[0009] where V_{th} is the threshold voltage of the drive transistor, μ the mobility of the semiconductor thin film making up the drive transistor's channel, W the channel width, L the channel length, C_{ox} the gate capacitance per unit area, and V_{gs} the gate-to-source voltage applied to the gate relative to the source.

[0010] On the other hand, as a gate potential V_g of the drive transistor rises as a result of the writing of an input signal voltage V_{sig} by the write transistor through sampling, a source potential V_s of the drive transistor will rise because of the coupling of the holding capacitance and the capacitance of the organic EL element. Here, letting the capacitance value of the holding capacitance be denoted by C_{cs} , the capacitance value of the organic EL element by C_{oled} and the increment of the gate potential V_g of the drive transistor by ΔV_g , an increment ΔV_s of the source potential V_s of the drive transistor is given by the following formula (2):

$$\Delta V_s = \Delta V_g \times \{C_{cs} / (C_{oled} + C_{cs})\} \quad (2)$$

[0011] As is clear from the formula (2), if the capacitance value C_{oled} of the organic EL element is sufficiently larger than the capacitance value C_{cs} of the holding capacitance, the increment ΔV_s of the source potential V_s of the drive transistor can be suppressed when the gate potential V_g of the drive transistor rises. That is, when sufficiently larger than the capacitance value C_{cs} of the holding capacitance, the capacitance value C_{oled} of the organic EL element is advantageous in providing a large gate-to-source potential difference of the drive transistor.

[0012] The reason for this is as follows. That is, if a large gate-to-source potential difference of the drive transistor can be provided at the time of writing of the input signal voltage V_{sig} by the write transistor, the amplitude of the input signal voltage V_{sig} written to the pixel can be reduced to the same extent. Hence, power consumption of horizontal drive system adapted to supply the input signal voltage V_{sig} to each pixel via a signal line can be reduced. As a result, the display device as a whole can be reduced in power consumption.

[0013] In light of the foregoing, it is an object of the present invention to provide a display device which permits the capacitance value of the electro-optical element such as organic EL element to be arbitrarily set without changing the light extraction efficiency of the pixel, and to provide an electro-optical element driving method and electronic equipment.

[0014] A display device according to the present invention is characterized as follows. That is, pixels, containing an electro-optical element and light-shielding film, are arranged in a matrix form. The light-shielding film forms a light extraction opening whose opening area is smaller than the light

emission area of the electro-optical element. The capacitance value of the electro-optical element is set by the light emission area of the electro-optical element.

[0015] An electro-optical element driving method according to the present invention is a driving method of an electro-optical element adapted to emit light according to the current. The electro-optical element driving method is characterized as follows. That is, the method drives a plurality of electro-optical elements and brings drive current value of each electro-optical element to approximately the same level by varying the light emission area between the electro-optical elements.

[0016] Electronic equipment according to the present invention is characterized in having a display device. In the display device, pixels, containing an electro-optical element and light-shielding film, are arranged in a matrix form. The light-shielding film forms a light extraction opening whose opening area is smaller than the light emission area of the electro-optical element. The capacitance value of the electro-optical element is set by the light emission area of the electro-optical element.

[0017] In the display device, electro-optical element driving method and electronic equipment configured as described above, the capacitance value of the electro-optical element is determined by the light-emitting material, the film thickness of the light-emitting layer, and the light emission area. For this reason, the capacitance value of the electro-optical element is set to an optimal value by adjusting the light emission area of the electro-optical element. In this case, the opening area of the light extraction opening formed by the light-shielding film is smaller than the light emission area of the electro-optical element. Therefore, even if the light emission area of the electro-optical element is changed, the light emission area of the pixel determined by the opening area of the light extraction opening, namely, the light extraction efficiency, will remain unchanged.

BRIEF DESCRIPTION OF DRAWINGS

[0018] FIG. 1 is a system configuration diagram illustrating the outline of the configuration of an active matrix organic EL display device according to the present invention.

[0019] FIG. 2 is a circuit diagram illustrating an example of circuit configuration of a pixel (pixel circuit).

[0020] FIG. 3 is a characteristic diagram of a drain-to-source voltage V_{ds} vs. drain-to-source current I_{ds} of a drive transistor.

[0021] FIG. 4 is a timing waveform diagram for describing the circuit operation of the active matrix organic EL display device according to the present invention.

[0022] FIG. 5 is a sectional view illustrating an example of sectional structure of the pixel.

[0023] FIG. 6 is a view illustrating the relationship between the change in light emission area of an organic EL element and the change in a capacitance value C_{oled} thereof.

[0024] FIG. 7 is a perspective view illustrating a television set to which the present invention is applied.

[0025] FIG. 8 is a perspective view illustrating a digital camera, to which the present invention is applied, and (A) is a perspective view as seen from the front, and (B) is a perspective view as seen from the rear.

[0026] FIG. 9 is a perspective view illustrating a laptop personal computer to which the present invention is applied.

[0027] FIG. 10 is a perspective view illustrating a video camcorder to which the present invention is applied.

[0028] FIG. 11 is a perspective view illustrating a mobile phone to which the present invention is applied, and (A) is a front view of the mobile phone in an open position, (B) is a side view thereof, (C) is a front view of the mobile phone in a closed discharge, (D) is a left side view, (E) is a right side view, (F) is a top view, and (G) is a bottom view.

BEST MODE FOR CARRYING OUT THE INVENTION

[0029] An embodiment of the present invention will be described in details with reference to the drawings.

[0030] FIG. 1 is a system configuration diagram illustrating the outline of the configuration of an active matrix display device according to the present invention such as active matrix organic EL display device.

[0031] As illustrated in FIG. 1, an organic EL display device 10 according to the present invention includes a pixel array section 30. The pixel array section 30 has pixels (pixel circuits) 20 containing an electro luminescence element, i.e., organic EL element 21 (refer to FIG. 2) as a light emitting element, arranged two-dimensionally in a matrix form. The organic EL element 21 is a current-driven electro-optical element whose light emission brightness changes with change in current value flowing through the device.

[0032] The pixel array section 30 is typically formed on a transparent insulating substrate such as glass substrate. The pixel array section 30 has scan lines 31-1 to 31-m, drive lines 32-1 to 32-m and first and second correction scan lines 33-1 to 33-m and 34-1 to 34-m for each of the pixels arranged in m rows by n columns. The pixel array section 30 also has signal lines (data lines) 35-1 to 35-n for each pixel column.

[0033] Several circuits are disposed around the pixel array section 30. These circuits are a write scan circuit 40 adapted to scan and drive the scan lines 31-1 to 31-m, a drive scan circuit 50 adapted to scan and drive the drive lines 32-1 to 32-m, first and second correction scan circuits 60 and 70 adapted to scan and drive the first and second correction scan lines 33-1 to 33-m and 34-1 to 34-m, and a horizontal drive circuit 80 adapted to supply a video signal (data signal, i.e., input signal) appropriate to brightness information to the signal lines 35-1 to 35-n.

[0034] To scan and drive the scan lines 31-1 to 31-m, drive lines 32-1 to 32-m and first and second correction scan lines 33-1 to 33-m and 34-1 to 34-m, the write scan circuit 40, drive scan circuit 50 and first and second correction scan circuits 60 and 70 output, as appropriate, write signals WS1 to WSm, drive signals DS1 to DSm and first and second correction scan signals AZ11 to AZ1m and AZ21 to AZ2m.

[0035] Each of the pixels 20 of the pixel array section 30 can be formed with an amorphous silicon TFT (thin film transistor) or low-temperature polysilicon TFT. Here, a case will be described as an example where the pixels 20 are formed with low-temperature polysilicon TFTs. In the case where low-temperature polysilicon TFTs are used, the write scan circuit 40, drive scan circuit 50, first and second correction scan circuits 60 and 70 and horizontal drive circuit 80 can also be formed integrally on a panel (substrate) on which pixel array section 30 is formed.

(Pixel Circuit)

[0036] FIG. 2 is a circuit diagram illustrating an example of circuit configuration of the pixel (pixel circuit) 20. As illustrated in FIG. 2, the pixel 20 includes, in addition to the

current-driven electro-optical element, i.e., organic EL element **21**, a drive transistor **22**, write (sampling) transistor **23**, switching transistors **24** to **26** and holding capacitance **27**, as its circuit components.

[0037] In the pixel **20** configured as described above, N-channel TFTs are used as the drive transistor **22**, write transistor **23** and switching transistors **25** and **26**. A P-channel TFT is used as the switching transistor **24**. It should be noted, however, that the combination of conductivity types of the drive transistor **22**, write transistor **23** and switching transistors **24** to **26** given here is merely an example, and the present invention is not limited to this combination.

[0038] The organic EL element **21** has its cathode electrode connected to a source potential VSS (ground potential GND in this case). The drive transistor **22** is adapted to current-drive the organic EL element **21**. The drive transistor **22** has its source connected to the anode electrode of the organic EL element **21**, thus forming a source-follower circuit. That is, the source potential V_s of the drive transistor **22** is determined by the operating point between the drive transistor **22** and organic EL element **21** as illustrated in FIG. 3. The source potential V_s has a different voltage value depending on the gate potential V_g .

[0039] The write transistor **23** has its source connected to the signal line **35** (**35-1** to **35-n**), its drain connected to the gate of the drive transistor **22**, and its gate connected to the scan line **31** (**31-1** to **31-m**). The switching transistor **24** has its source connected to a second source potential VDD (positive source potential in this case), its drain connected to the drain of the drive transistor **22**, and its gate connected to the drive line **32** (**32-1** to **32-m**). The switching transistor **25** has its drain connected to a third source potential V_{in1} , its source connected to the drain of the write transistor **23** (gate of the drive transistor **22**), and its gate connected to the first correction scan line **33** (**33-1** to **33-m**).

[0040] The switching transistor **26** has its drain connected to a connection node N11 between the source of the drive transistor **22** and the anode electrode of the organic EL element **21**, its source connected to a fourth source potential V_{in2} (negative source potential in this case), and its gate connected to the second correction scan line **34** (**34-1** to **34-m**). The holding capacitance **27** has one end connected to a connection node N12 between the gate of the drive transistor **22** and the drain of the write transistor **23**. The holding capacitance **27** has the other end connected to the connection node N11 between the source of the drive transistor **22** and the anode electrode of the organic EL element **21**.

[0041] In the pixel **20** whose components are connected according to the above connection relationship, each of the components serves the following function. That is, the write transistor **23** conducts to sample the input signal voltage V_{sig} supplied via the signal line **35** and write the input signal voltage V_{sig} to the pixel **20**. The written input signal voltage V_{sig} is held by the holding capacitance **27**. The switching transistor **24** conducts to supply a current to the drive transistor **22** from the source potential VDD.

[0042] When the switching transistor **24** is conducting, the drive transistor **22** supplies a current appropriate to the input signal voltage V_{sig} held by the holding capacitance **27** to the organic EL element **21**, thus driving the same organic EL element **21** (current driving). The switching transistors **25** and **26** conduct as appropriate to detect the threshold voltage V_{th} of the drive transistor **22** ahead of the current driving of the organic EL element **21** and hold the detected threshold volt-

age V_{th} in the holding capacitance **27** so as to cancel the impact of the current driving in advance. The holding capacitance **27** holds the gate-to-source potential difference of the drive transistor **22** over the display period.

[0043] As a condition to guarantee the proper operation of the pixel **20**, the fourth source potential V_{in2} is set lower than the potential obtained by subtracting the threshold voltage V_{th} of the drive transistor **22** from the third source potential V_{in1} . That is, the level relationship, $V_{in2} < V_{in1} - V_{th}$, holds. Further, the level obtained by adding a threshold voltage V_{thel} of the organic EL element **21** to a cathode potential V_{cat} (ground potential GND in this case) of the organic EL element **21** is set higher than the level obtained by subtracting the threshold voltage V_{th} of the drive transistor **22** from the third source potential V_{in1} . That is, the level relationship, $V_{cat} + V_{thel} > V_{in1} - V_{th} (> V_{in2})$, holds.

[Description of the Circuit Operation]

[0044] A description will be given next of the circuit operation of the active matrix organic EL display device **10** having the pixels **20** configured as described above arranged two-dimensionally in a matrix form with reference to the timing waveform diagram in FIG. 4.

[0045] FIG. 4 illustrates the timing relationship between the write signal WS (WS_1 to WS_m) given to the pixel **20** by the write scan circuit **40**, the drive signal DS (DS_1 to DS_m) given to the pixel **20** by the drive scan circuit **50**, and the first and second correction scan signals AZ_1 (AZ_{11} to AZ_{1m}) and AZ_2 (AZ_{21} to AZ_{2m}) given to the pixel **20** by the first and second correction scan circuits **60** and **70**, and the changes of the gate potential V_g and source potential V_s of the drive transistor **22** when the pixels **20** on a column are driven.

[0046] Here, the write transistor **23** and switching transistors **25** and **26** are N-channel transistors. Therefore, the write signal WS and first and second correction scan signals AZ_1 and AZ_2 are in an active state at high level (source potential VDD in this example; hereinafter written as "H" level) and in an inactive state at low level (source potential VSS (GND) in this example; hereinafter written as "L" level). Further, the switching transistor **24** is a P-channel transistor. Therefore, the drive signal DS is in an active state at "L" level and in an inactive state at "H" level.

[0047] At time t_1 , the drive signal DS changes from "L" level to "H" level, bringing the switching transistor **24** out of conduction. At time t_2 , the second correction scan signal AZ_2 changes from "L" level to "H" level, bringing the switching transistor **26** into conduction. As a result, the source potential V_{in2} is applied to the source of the drive transistor **22** via the switching transistor **26**.

[0048] At this time, the level relationship, $V_{in2} < V_{cat} + V_{thel}$, holds as mentioned earlier. Therefore, the organic EL element **21** is in a reverse-biased state. As a result, no current flows through the organic EL element **21**, causing it not to emit light.

[0049] Next, at time t_3 , the first correction scan signal AZ_1 changes from "L" level to "H" level, bringing the switching transistor **25** into conduction. Therefore, the source potential V_{in1} is applied to the gate of the drive transistor **22** via the switching transistor **25**. At this time, the gate-to-source voltage V_{gs} of the drive transistor **22** takes on the value of $V_{in1} - V_{in2}$. Here, the level relationship, $V_{in1} - V_{in2} > V_{th}$, is satisfied.

(V_{th} Correction Period)

[0050] Next, at time t₄, the second correction scan signal AZ2 changes from “H” level to “L” level, bringing the switching transistor 26 out of conduction. Then, at time t₅, the drive signal DS changes from “H” level to “L” level, bringing the switching transistor 24 into conduction. As a result, a current appropriate to the gate-to-source potential difference V_{gs} of the drive transistor 22 flows through the drive transistor 22.

[0051] At this time, the cathode potential V_{cat} (source potential VSS) of the organic EL element 21 is higher than the source potential V_s of the drive transistor 22. Therefore, the organic EL element 21 is in a reverse-biased state. As a result, the current from the drive transistor 22 flows in the following order, i.e., the node N11, holding capacitance 27, node N12, switching transistor 25, and source potential V_{ini1}. Therefore, a charge appropriate to the current is stored in the holding capacitance 27. On the other hand, as the holding capacitance 27 is charged, the source potential V_s of the drive transistor 22 will rise gradually from the source potential V_{ini2} over time.

[0052] Then, when, after elapse of a given time, the gate-to-source (N11-to-N12) potential difference V_{gs} of the drive transistor 22 becomes equal to the threshold voltage V_{th} of the same drive transistor 22, the same drive transistor 22 will go into cutoff. Therefore, a current stops flowing through the drive transistor 22. As a result, the gate-to-source (N11-to-N12) potential difference V_{gs} of the drive transistor 22, i.e., the threshold voltage V_{th}, is held by the holding capacitance 27 as a threshold correction potential.

[0053] Then, at time t₆, the drive signal DS changes from “L” level to “H” level, bringing the switching transistor 24 out of conduction. This period from time t₅ to time t₆ is a period of time during which the threshold voltage V_{th} of the drive transistor 22 is detected and held by the holding capacitance 27. Here, this given period t₅ to t₆ will be referred to as the V_{th} correction period for the sake of convenience. Then, at time t₇, the first correction scan signal AZ1 changes from “H” level to “L” level, bringing the switching transistor 25 out of conduction.

(Write Period)

[0054] Next, at time t₈, the write signal WS changes from “L” level to “H” level, causing the write transistor 23 to sample the input signal voltage V_{sig} and write this signal to the pixel. As a result, the gate potential V_g of the drive transistor 22 becomes equal to the input signal voltage V_{sig}. The input signal voltage V_{sig} is held by the holding capacitance 27.

[0055] At this time, the source potential V_s of the drive transistor 22 rises due to the capacitive coupling between the holding capacitance 27 and organic EL element 21 relative to the amplitude of the gate potential V_g of the drive transistor 22 at the time of sampling by the write transistor 23. The increment ΔV_s of the source potential V_s of the drive transistor 22 is expressed by the formula (2) mentioned earlier.

[0056] The input signal voltage V_{sig} written by the write transistor 23 is held by the holding capacitance 27 so that the input signal voltage V_{sig} is added to the threshold voltage V_{th} held by the holding capacitance 27. At this time, the voltage held by the holding capacitance 27 is equal to V_{sig}-V_{ini1}+V_{th}. Here, for easier understanding, we assume that V_{ini1}=0 V. Then, the gate-to-source voltage V_{gs} is equal to V_{sig}+V_{th}.

[0057] As described above, the variation of the threshold voltage V_{th} of the drive transistor 22 between pixels and the change of the threshold voltage V_{th} over time can be corrected by holding the threshold voltage V_{th} in the holding capacitance 27 in advance. That is, when the drive transistor 22 is driven by the input signal voltage V_{sig}, the threshold voltage V_{th} of the drive transistor 22 and the threshold voltage V_{th} held by the holding capacitance 27 cancel each other. In other words, the threshold voltage V_{th} is corrected.

[0058] This correction operation of the threshold voltage V_{th} permits cancellation of the impact of the threshold voltage V_{th} on the driving of the organic EL element 21 by the drive transistor 22 even if there is a variation of the threshold voltage V_{th} between pixels or a change of the threshold voltage V_{th} over time. As a result, the light emission brightness of the organic EL element 21 can be maintained constant without being affected by the variation of the threshold voltage V_{th} or the change thereof over time.

(Mobility Correction Period)

[0059] Then, at time t₉, the drive signal DS changes from “H” level to “L” level with the write transistor 23 remaining in conduction, bringing the switching transistor 24 into conduction. As a result, the supply of a current from the source potential VDD to the drive transistor 22 begins. It should be noted that this period from time t₈ to time t₉ is one horizontal interval (1H). Here, the organic EL element 21 is put into a reverse-biased state by setting V_{ini1}-V_{th}<V_{thel}.

[0060] When the organic EL element 21 is put into a reverse-biased state, the organic EL element 21 exhibits a simple capacitive characteristic rather than diode characteristic. Therefore, the drain-to-source current I_{ds} flowing through the drive transistor 22 is written to a combined capacitance C (=C_{cs}+C_{oled}) of the capacitance value C_{cs} of the holding capacitance 27 and the capacitance value C_{oled} of the organic EL element 21. This writing causes the source potential V_s of the drive transistor 22 to rise.

[0061] The increment ΔV_s of the source potential V_s of the drive transistor 22 acts so that it is subtracted from the gate-to-source potential difference V_{gs} of the drive transistor 22 held by the holding capacitance 27, in other words, in such a manner as to discharge the charge stored in the holding capacitance 27. This means that a negative feedback is applied. That is, the increment ΔV_s of the source potential V_s of the drive transistor 22 is a feedback amount of the negative feedback. At this time, the gate-to-source potential difference V_{gs} of the drive transistor 22 is V_{sig}- ΔV_s +V_{th}.

[0062] As described above, if the current flowing through the drive transistor 22 (drain-to-source current I_{ds}) is negatively fed back to the gate input (gate-to-source potential difference) of the drive transistor 22, the dependence of the drain-to-source current I_{ds} of the drive transistor 22 on the mobility μ in each of the pixels 20 can be cancelled. That is, the variation of the mobility μ of the drive transistor 22 can be corrected.

[0063] A period T (t₉ to t₁₀) during which the active period of the write signal WS (“H” level period) and the active period of the drive signal DS (“L” level period) overlap, namely, the overlapping period during which the write transistor 23 and switching transistor 24 are both conducting, is referred to as a mobility correction period.

[0064] Here, a drive transistor with the high mobility μ and another drive transistor with the low mobility μ are considered. The source potential V_s of the drive transistor with the

high mobility μ rises sharply as compared to that of the drive transistor with the low mobility μ in this mobility correction period T. Further, the larger the source potential V_s is, the smaller the gate-to-source potential difference of the drive transistor **22** becomes. As a result, a current is less likely to flow.

[0065] That is, it is possible to cause the same drain-to-source current I_{ds} to flow through the drive transistors **22** with the different mobilities μ by adjusting the mobility correction period T. The gate-to-source potential difference V_{gs} of the drive transistor **22** determined in the mobility correction period T is retained by the holding capacitance **27**. The current (drain-to-source current I_{ds}) appropriate to the gate-to-source potential difference V_{gs} flows from the drive transistor **22** to the organic EL element **21**. This allows the organic EL element **21** to emit light.

(Light Emission Period)

[0066] At time t_{10} , the write signal WS falls to "L" level, bringing the write transistor **23** out of conduction. As a result, the mobility correction period T ends, and a light emission period begins. In the light emission period, the source potential V_s of the drive transistor **22** rises to the driving voltage of the organic EL element **21**. As a result of the rise of the source potential V_s , the gate of the drive transistor **22** is disconnected from the signal line **35** (**35-1** to **35-n**) and left in a floating state. Therefore, the gate potential V_g will also rise via the holding capacitance **27**.

[0067] At this time, letting the parasitic capacitance of the gate of the drive transistor **22** be denoted by C_g , the increment ΔV_g of the gate potential V_g is expressed by the following formula (3):

$$\Delta V_g = \Delta V_s \times \{C_{cs} / (C_{cs} + C_g)\} \quad (3)$$

[0068] During this period, the gate-to-source potential difference V_{gs} held in the holding capacitance **27** maintains the value of $V_{sig} - \Delta V_s + V_{th}$.

[0069] Then, as the source potential V_s of the drive transistor **22** rises, the reverse bias is removed from the organic EL element **21**. Therefore, the constant drain-to-source current I_{ds} given by the aforementioned formula (1) flows from the drive transistor **22** to the organic EL element **21**, causing the organic EL element **21** to actually start emitting light.

[0070] The relationship between the drain-to-source current I_{ds} and gate-to-source potential difference V_{gs} at this time is given by the following formula (4) by substituting $V_{sig} - \Delta V_s + V_{th}$ into V_{gs} in the formula (1).

$$I_{ds} = k\mu(V_{gs} - V_{th})^2 = k\mu(V_{sig} - \Delta V)^2 \quad (4)$$

[0071] In the above formula (4), $k = (1/2)(W/L)Cox$.

[0072] As is clear from the formula (4), the term of the threshold voltage V_{th} of the drive transistor **22** is cancelled. The drain-to-source current I_{ds} supplied from the drive transistor **22** to the organic EL element **21** is independent of the threshold voltage V_{th} of the drive transistor **22**. Basically, the drain-to-source current I_{ds} is determined by the input signal voltage V_{sig} . In other words, the organic EL element **21** emits light at the brightness appropriate to the input signal voltage V_{sig} without being affected by the variation of the threshold voltage V_{th} of the drive transistor **22** or the change thereof over time.

[0073] Further, as is clear from the formula (4), the input signal voltage V_{sig} is corrected with the feedback amount ΔV_s by negatively feeding back the drain-to-source current

I_{ds} to the gate input of the drive transistor **22**. The feedback amount ΔV_s acts to cancel the effect of the mobility μ in the coefficient part of the formula (4). Therefore, the drain-to-source current I_{ds} is substantially dependent only on the input signal voltage V_{sig} . That is, the organic EL element **21** emits light at the brightness appropriate to the input signal voltage V_{sig} without being affected by the variation of the threshold voltage V_{th} of the drive transistor **22** or mobility μ of the drive transistor **22** or the change thereof over time. This provides uniform image quality free from banding or uneven brightness.

[0074] Here, in the active matrix display device having the pixels **20**, containing a current-driven electro-optical element, i.e., the organic EL element **21**, arranged in a matrix form, if the light emission time of the organic EL element **21** is long, the I-V characteristic of the organic element **21** will change. For this reason, the connection node **N11** between the anode electrode of the organic EL element **21** and the source of the drive transistor **22** will also change in potential.

[0075] In contrast, in the active matrix organic EL display device **10** configured as described above, the gate-to-source potential difference V_{gs} of the drive transistor **22** is maintained constant. For this reason, the current flowing through the organic EL element remains unchanged. Therefore, the constant drain-to-source current I_{ds} will continue to flow through the organic EL element **21** even if the I-V characteristic of the organic EL element **21** deteriorates. As a result, the light emission brightness of the organic EL element **21** will remain unchanged (compensation function for a characteristic change of the organic EL element **21**).

[0076] Further, the threshold voltage V_{th} of the drive transistor **22** is held by the holding capacitance **27** before the writing of the input signal voltage V_{sig} . As a result, the threshold voltage V_{th} of the drive transistor **22** can be cancelled (corrected) so that the constant drain-to-source current I_{ds} flows through the organic EL element **21** without being affected by the variation of the threshold voltage V_{th} or the change thereof over time. This provides a high quality display image (compensation function for the variation of V_{th} of the drive transistor **22**).

[0077] Still further, in the mobility correction period t_9 to t_{10} , the drain-to-source current I_{ds} is negatively fed back to the gate input of the drive transistor **22** so that the input signal voltage V_{sig} is corrected with the feedback amount ΔV_s . As a result, the dependence of the drain-to-source current I_{ds} of the drive transistor **22** on the mobility μ is cancelled, thus allowing the drain-to-source current I_{ds} , which is dependent only on the input signal voltage V_{sig} , to flow through the organic EL element **21**. This ensures uniform display image quality free from banding or uneven brightness caused by the variation of the mobility μ of the drive transistor **22** or the change thereof over time (compensation function for the mobility μ of the drive transistor **22**).

[0078] Incidentally, if the capacitance value C_{oled} of the organic EL element **21** is sufficiently larger than the capacitance value C_{cs} of the holding capacitance **27**, the increment ΔV_s of the source potential V_s of the drive transistor can be suppressed when the gate potential V_g of the drive transistor rises as described earlier. Therefore, when sufficiently larger than the capacitance value C_{cs} , the capacitance value C_{oled} is advantageous in providing the large gate-to-source potential difference V_{gs} of the drive transistor.

[0079] For this reason, the present invention is characterized in that it permits the capacitance value C_{oled} of the

organic EL element **21** to be arbitrarily set without changing the light extraction efficiency of the pixel **20** so that the capacitance value C_{oled} of the organic EL element **21** can be set sufficiently larger than the capacitance value C_{cs} of the holding capacitance **27**.

(Pixel Structure)

[0080] FIG. 5 is a sectional view illustrating an example of sectional structure of the pixel **20**. As illustrated in FIG. 5, the pixel **20** includes a substrate **51** on which the drive transistor **22**, write transistor **23**, switching transistors **24** to **26** and other components are formed. The pixel **20** further includes an insulating film **52** formed on the substrate **51** and is configured to have the organic EL element **21** disposed in a concave portion **52A** of the insulating film **52**.

[0081] The organic EL element **21** includes a first electrode (e.g., anode electrode) **53** made up of a metal or other substance formed on the bottom portion of the concave portion **52A** of the insulating film **52**. The organic EL element **21** further includes an organic layer **54** formed on the first electrode **53** and a second electrode (e.g., cathode electrode) **55** formed commonly for all the pixels on the organic layer **54** and made up, for example, of a transparent conductive film.

[0082] In the organic EL element **21**, the organic layer **54** is formed by stacking a hole transporting layer, light-emitting layer, electron transporting layer and electron injection layer successively in this order on the first electrode **53**. Then, a current flows from the drive transistor **22** shown in FIG. 2 to the organic layer **54** via the first electrode (anode electrode) **53**. This causes electrons and holes to recombine in the light-emitting layer of the organic layer **54**, thus causing light to be emitted.

[0083] On the top surface of the organic EL element **21**, i.e., the top surface of the second electrode (transparent electrode) **55** is formed with a light-shielding film **57** which is referred to as so-called "black matrix." The light-shielding film **57**, which is patterned on a pixel-by-pixel basis, forms a light extraction opening **56** whose opening area is smaller than the light emission area of the organic EL element **21**, i.e., the surface area of the organic layer **54**. The light-shielding film **57** acts to suppress the optical interference between the adjacent pixels, thus providing improved contrast ratio.

[0084] That is, when the organic EL element **21** emits light, the area from which light can be extracted is the opening area of the light extraction opening **56** where the light-shielding film **57** is not disposed. That is, light cannot be extracted from the organic EL element **21** located where the light-shielding film **57** is disposed, in other words, outside the light extraction opening **56** even if the organic EL element **21** emits light. That is, the opening area of the light extraction opening **56** is the light emission area of the pixel **20**.

[0085] In the pixel **20** configured as described above, the capacitance value C_{oled} of the organic EL element **21** is proportional to the light emission area of the organic EL element **21** (surface area of the organic layer **54**). Therefore, the capacitance value C_{oled} of the organic EL element **21** can be increased by increasing the light emission area of the organic EL element **21**. More specifically, if the light emission area of the organic EL element **21** is increased from the condition in FIG. 6A to that in FIG. 6B, the capacitance value C_{oled} of the organic EL element **21** will increase by as much as the light emission area is increased (higher EL capacitance).

[0086] Even if the light emission area of the organic EL element **21** is increased, the light extraction efficiency of the pixel **20** will remain the same as before the light emission area of the organic EL element **21** is increased. The reason for this is as follows. That is, when the light emission area of the organic EL element **21** is increased, the area of the organic layer **54** will spread out under the light-shielding film **57**. The light emitted by the spread portion is shielded by the light-shielding film **57**. Therefore, the light extraction efficiency of the pixel **20** is determined by the opening area of the light extraction opening **56**, irrespective of the light emission area of the organic EL element **21** (surface area of the organic layer **54**).

[0087] As described above, the organic EL display device has the pixels **20** arranged in a matrix form. The pixel **20** has the light extraction opening **56** formed therein whose opening area is smaller than the light emission area of the organic EL element **21**. The light extraction opening **56** is formed by the light-shielding film (black matrix) **57** on the pixel surface. In this organic EL display device, the capacitance value C_{oled} of the organic EL element **21** can be arbitrarily set by adjusting the light emission area of the organic EL element **21**. This permits the capacitance value C_{oled} of the organic EL element **21** to be set sufficiently larger than the capacitance value C_{cs} of the holding capacitance **27** without changing the light extraction efficiency of the pixel **20**.

[0088] If the capacitance value C_{oled} of the organic EL element is sufficiently larger than the capacitance value C_{cs} of the holding capacitance, the increment ΔV_s of the source potential V_s can be suppressed when the gate potential V_g of the drive transistor **22** rises as is clear from the formula (2). This provides the large gate-to-source potential difference V_{gs} of the drive transistor **22**.

[0089] As described above, if the large gate-to-source potential difference V_{gs} of the drive transistor **22** can be provided at the time of writing of the input signal voltage V_{sig} by the write transistor **22**, the amplitude of the input signal voltage V_{sig} written to the pixel **20** can be reduced to the same extent. Hence, the horizontal drive circuit **80**, adapted to supply the input signal voltage V_{sig} to each pixel **20** on the row selected by the write scan circuit **40** via the signal line **35** (**35-1** to **35-n**), can be reduced in power consumption. As a result, the display device as a whole can be reduced in power consumption.

[0090] On the other hand, if, in the color organic EL display device, the pixels **20** are arranged so that at least two colors, and for example three colors, namely, R (red), G (green) and B (blue), are grouped as one unit, the organic EL elements **21** adapted to emit the respective colors have the different capacitance values C_{oled} because they are made of different materials and have different film thicknesses.

[0091] In the organic EL element **21** whose structure is shown in FIG. 5, the emission color is determined, for example, by the material used to form the light-emitting layer of the organic layer **54** and a thickness t of the organic layer **54**. In other words, the organic EL elements adapted to emit each color of R, G and B differ in the material of the organic EL element or film thickness t from one another. The difference in the material of the organic EL element or film thickness t changes the capacitance C_{oled} of the organic EL element. That is, the difference in the material or film thickness t between the organic EL elements adapted to emit the respective colors leads to a difference in the capacitance C_{oled} therebetween.

[0092] As an example, the relationship in magnitude of the film thickness t of the organic EL element, $R > G > B$, holds because of the relationship in magnitude of wavelength ($R > G > B$) between the three colors of R, G and B. Therefore, the relationship in magnitude of the capacitance C_{oled} of the organic EL element, $B > G > R$, holds, with B having the largest capacitance C_{oled} , which is the opposite of the film thickness. The ratio of capacitance is, for example, $R:G:B=1:1.2:1.5$.

[0093] For this reason, the light emission area is adjusted for each of the organic EL elements adapted to emit each color of R, G and B. For example, the light emission areas of G and R are increased successively in this order relative to the light emission area of B so that the capacitance C_{oled} of the organic EL element is the same for all the colors. As a result, when the gate potential V_g of the drive transistor **22** rises as a result of the writing of the signal voltage V_{sig} by the write transistor **23** through sampling, the increment ΔV_s of the source potential V_s of the drive transistor **22** resulting from the coupling of the holding capacitance **27** and the capacitance of the organic EL elements **21** will be the same between each pixel of R, G and B.

[0094] Further, if the capacitance C_{oled} of the organic EL element **21** is different depending on the emission color, the increment ΔV_s of the source potential V_s of the drive transistor **22** will be different between R, G and B even when the increment ΔV_g of the gate potential V_g of the drive transistor **22** is the same for R, G and B, as is clear from the formula (2) described earlier. As a result, even if the input signal voltage V_{sig} of the same level (voltage value) is fed to each R, G and B pixel, the drive voltages of each R, G and B organic EL element will not reach the voltage value appropriate to the signal voltage V_{sig} , thus resulting in an improper white balance.

[0095] The term "improper white balance" means that even if the input signal voltage V_{sig} adapted to display white is fed to each R, G and B pixel, the display colors of each R, G and B pixel will not combine into completely white. An improper white balance makes it impossible to produce images with natural-looking color.

[0096] Also in such a case, the light emission area is varied between the organic EL elements adapted to emit each color of R, G and B (between the pixels emitting the different colors). By doing so, the change between the gate-to-source potential difference V_{gs} when the input signal is written and the gate-to-source potential difference V_{gs} when the organic EL element **21** emits light is adjusted. As a result, the drive voltages of the organic EL elements **21** of the respective colors will be voltage values appropriate to the input signal voltage V_{sig} in accordance with the input of the input signal voltage V_{sig} of the same level. This ensures that the drive current values of the organic EL elements **21** of the respective colors will be approximately the same, thus allowing maintaining a proper white balance. As a result, images with more natural-looking color can be produced.

[0097] Here, red, green and blue were used as a plurality of the three basic colors as a unit for image display. However, the present invention is not limited to the combination of these three colors, but other color such as white may be added to the three colors to produce a four-color combination. Alternatively, other colors may be combined together.

[0098] It should be noted that the pixel circuit (pixel) of the organic EL display device to which the present invention is applicable is not limited to the example of the pixel circuit

shown in FIG. 2. Instead, the present invention is applicable to all circuits in which the source potential V_s of the drive transistor **22** rises because of the coupling of the holding capacitance **22** and the capacitance of the organic EL element **21** at the time of writing of the signal to the gate of the drive transistor **22**.

[0099] Further, although the above embodiment has been described taking, as an example, a case in which the present invention is applied to the organic EL display device using the organic EL element **21** as an electro-optical element of the pixel **20**, the present invention is not limited to this application example. Instead, the present invention is applicable to all display devices in general using current-driven electro-optical elements (luminescence elements) whose light emission brightness changes with change in a current value flowing through the device.

APPLICATION EXAMPLES

[0100] The display device according to the present invention described above is applicable as a display device of electronic equipment across all fields including those shown in FIGS. 7 to 11, namely, a digital camera, laptop personal computer, mobile terminal device such as mobile phone and video camcorder. These pieces of equipment are designed to display an image or video of a video signal fed to or generated inside the electronic equipment. Examples of electronic equipment to which the present invention is applied will be described below.

[0101] It should be noted that the display device according to the present invention includes that in a modular form having a sealed configuration. For example, such a display device corresponds to a display module formed by attaching an opposed section made, for example, of transparent glass to the pixel array section **30**. The aforementioned light-shielding film may be provided on the transparent opposed section, in addition to films such as color filter and protective film. It should be noted that a circuit section, FPC (flexible printed circuit) or other circuitry, adapted to allow exchange of signals or other information between external equipment and the pixel array section, may be provided on the display module.

[0102] FIG. 7 is a perspective view illustrating a television set to which the present invention is applied. The television set according to the present application example includes a video display screen section **101** made up, for example, of a front panel **102**, filter glass **103** and other parts. The television set is manufactured by using the display device according to the present invention as the video display screen section **101**.

[0103] FIG. 8 is a perspective view illustrating a digital camera to which the present invention is applied. (A) is a perspective view of the digital camera as seen from the front side, and (B) is a perspective view thereof as seen from the rear side. The digital camera according to the present application example includes a light-emitting section **111** for flash, display section **112**, menu switch **113**, shutter button **114** and other parts. The digital camera is manufactured by using the display device according to the present invention as the display section **112**.

[0104] FIG. 9 is a perspective view illustrating a laptop personal computer to which the present invention is applied. The laptop personal computer according to the present application example includes, in a main body **121**, a keyboard **122** adapted to be manipulated for entry of text or other information, a display section **123** adapted to display an image, and

other parts. The laptop personal computer is manufactured by using the display device according to the present invention as the display section 123.

[0105] FIG. 10 is a perspective view illustrating a video camcorder to which the present invention is applied. The video camcorder according to the present application example includes a main body section 131, lens 132 provided on the front-facing side surface to image the subject, imaging start/stop switch 133, display section 134 and other parts. The video camcorder is manufactured by using the display device according to the present invention as the display section 134.

[0106] FIG. 11 is a perspective view illustrating a mobile terminal device such as mobile phone to which the present invention is applied. (A) is a front view of the mobile phone in an open position. (B) is a side view thereof. (C) is a front view of the mobile phone in a closed discharge. (D) is a left side view. (E) is a right side view. (F) is a top view. (G) is a bottom view. The mobile phone according to the present application example includes an upper enclosure 141, lower enclosure 142, connecting section (hinge section in this example) 143, display 144, sub-display 145, picture light 146, camera 147 and other parts. The mobile phone is manufactured by using the display device according to the present invention as the display 144 and sub-display 145.

[0107] The present invention permits the capacitance value of the electro-optical element to be arbitrarily set without changing the light extraction efficiency of the pixel by adjusting the light emission area of the electro-optical element.

What is claimed is:

1. A light emitting apparatus comprising:
 - a plurality of pixels arranged in a matrix form, at least one of the plurality of pixels comprising:
 - an electro-optical element including an anode electrode, a light emitting layer and a cathode electrode;
 - a drive transistor configured to drive the electro-optical element;
 - a holding capacitor configured to hold an input signal voltage for supply to the drive transistor;
 - a first switching transistor connected between a high potential line and the drive transistor;
 - a second switching transistor connected between a low potential line and the anode electrode; and
 - an opening definition layer configured to define a light extraction area,
 - the light extraction area being smaller than an area on which the electro-optical element is disposed, wherein the plurality of pixels includes a first pixel and a second pixel,
 - the first pixel includes a first electro-optical element configured to emit green light,

the second pixel includes a second electro-optical element configured to emit blue light,

the first electro-optical element has a first light emitting layer,

the second electro-optical element has a second light emitting layer,

a first light extraction area of the first pixel is smaller than a first area on which the first electro-optical element is disposed,

a second light extraction area of the second pixel is smaller than a second area on which the second electro-optical element is disposed,

the first light emitting layer is thicker than the second light emitting layer, and

the first area is larger than the second area.

2. The light emitting apparatus according to claim 1, wherein a capacitance of the electro-optical element is larger than a capacitance of the holding capacitor.

3. The light emitting apparatus according to claim 1, wherein the opening definition layer includes a black matrix.

4. The light emitting apparatus according to claim 1, wherein the first switching transistor is a P-channel transistor.

5. The light emitting apparatus according to claim 1, wherein the second switching transistor is a N-channel transistor.

6. An electronic device comprising the light emitting apparatus of claim 1.

7. The light emitting apparatus according to claim 1, wherein the plurality of pixels further includes a third pixel, the third pixel includes a third electro-optical element configured to emit red light, the third electro-optical element has a third light emitting layer, and a third light extraction area of the third pixel is smaller than a third area on which the third electro-optical element is disposed.

8. The light emitting apparatus according to claim 7, wherein the third light emitting layer is thicker than the first light emitting layer.

9. The light emitting apparatus according to claim 7, wherein the third light emitting layer is thicker than the second light emitting layer.

10. The light emitting apparatus according to claim 7, wherein the third area is larger than the first area.

11. The light emitting apparatus according to claim 7, wherein the third area is larger than the second area.

12. The light emitting apparatus according to claim 1, wherein a capacitance value of the first electro-optical element depends on the first area.

* * * * *

专利名称(译)	显示装置，电光元件驱动方法和电子设备		
公开(公告)号	US20150221673A1	公开(公告)日	2015-08-06
申请号	US14/686844	申请日	2015-04-15
[标]申请(专利权)人(译)	索尼公司		
申请(专利权)人(译)	索尼公司		
当前申请(专利权)人(译)	JOLED INC.		
[标]发明人	TOMIDA MASATSUGU		
发明人	TOMIDA, MASATSUGU		
IPC分类号	H01L27/12 G09G3/30 H01L27/15		
CPC分类号	G09G3/3233 H01L27/15 G09G2300/0842 G09G2300/0861 G09G2310/0256 G09G2320/043 H01L27/3265 H01L51/5284 H01L2251/5315 H01L27/1255 G09G2300/0408 G09G2300/0439 G09G2300/0809 G09G2310/0294 G09G2330/023 G09G3/30 G09G2300/0404 H01L27/124 G09G2300/0819		
优先权	2006306252 2006-11-13 JP PCT/JP2007/071559 2007-11-06 WO		
其他公开文献	US9224761		
外部链接	Espacenet USPTO		

摘要(译)

本发明允许在不改变像素的光提取效率的情况下任意设置诸如有机EL元件的电光元件的电容值。也就是说，本发明允许通过调节有机EL元件的发光面积来任意设定有机EL元件的电容值Coled (21) 21) 在不改变有机EL显示装置中像素 (20) 的光提取效率的情况下。有机EL显示装置具有以矩阵形式排列的像素 (20)。利用遮光膜 (黑矩阵) (57) 在像素的表面上形成光提取开口 (56)。光提取开口 (56) 的开口面积小于有机EL元件的发光面积 (21)。

